

SAFETY PRECAUTIONS ENCLOSED

DO NOT DESTROY

This manual contains important safety information and should be made available to all personnel who operate and/or maintain this product. Carefully read this manual before attempting to operate or perform maintenance.

PRECAUCIONES DE SEGURIDAD

NO DESTRUIR

Este manual contiene información importante y debe estar al alcance de todo el personal que opera y/o mantiene este producto. Lea cuidadosamente este manual antes de intentar operar o efectuar cualquier mantenimiento a este producto.

PARTS LIST

**Model 15T2
Three-Stage
High Pressure
Industrial
Air Compressor**

INGERSOLL-RAND®

AIR COMPRESSORS

NOTICE

THE USE OF REPAIR PARTS OTHER THAN THOSE INCLUDED WITHIN THE INGERSOLL-RAND COMPANY APPROVED PARTS LIST MAY CREATE UNSAFE CONDITIONS OR MECHANICAL FAILURES OVER WHICH INGERSOLL-RAND COMPANY HAS NO CONTROL. INGERSOLL-RAND COMPANY SHALL BEAR NO RESPONSIBILITY FOR EQUIPMENT ON WHICH NON-APPROVED REPAIRS PARTS ARE INSTALLED.

The manufacturer reserves the right to make changes or add improvements without notice and without incurring any obligation to make such changes or add such improvements to products previously sold.

GLOSSARY

Group Assembly Parts List

Parts are listed in disassembly sequence, where applicable. Each assembly is broken down into subassemblies and detail parts which are identified with "bullet" (•) symbols in the DESCRIPTION column to indicate the relationship to the next higher assembly:

Assemblies and Detail Parts

- Attaching Parts for Assemblies and Detail Parts
- • Subassemblies
- • • Detail Parts for Subassemblies, etc.

Reference Number Column

The reference number is the number assigned to the part in the listing. The reference number corresponds to the item on the associated illustration. Where applicable, the following abbreviations might appear in this column:

- NI Not Illustrated.
REF Reference Only. Refer to the figure and page noted in the description column.

Part Number Column

All numbers listed in this column are INGERSOLL-RAND part numbers, and must be specified when ordering replacement parts. The following abbreviations appear in this column:

- NA Not Applicable. This abbreviation indicates items which are not used on particular models or packages.
NSS Not Sold Separately. These items must be ordered under the next higher assembly, or, where applicable, as part of a Step Saver Kit.
* Consumable Materials (lubricants, sealants, etc.). Purchase directly from your local INGERSOLL-RAND Air Center or Full Service Distributor.
** Part Number Varies. Specify the compressor bare speed and complete nameplate data when ordering.

Description Column

The description column indicates the item by standard name followed by modifiers. The modifiers identify specific characteristics (i.e. dimensions, capacity, pressure setting, etc.), and/or the particular location or function on the compressor. Always include the description when ordering replacement parts or kits.

Quantity Per Assembly Column

Quantities listed in this column reflect the number used in the next higher assembly, and are not necessarily the total quantity of the part used in the complete package. Specify the desired quantity when ordering replacement parts.

Recommended Spares Column

Quantities listed in this column reflect the number of each item which we recommend be kept on hand for maintenance or repair.

- CLASS 1 MINIMUM. Recommended quantity for Domestic Service where interruptions in service are not important.
CLASS 2 AVERAGE. Recommended quantity for Domestic Service where interruptions in continuity of service are not objectionable.
CLASS 3 MAXIMUM. Recommended quantity for International or Domestic Service where interruptions in service are not acceptable.

Step Saver Kits

Step Saver Kits are available for all compressor models. These kits are designed to provide all of the parts you will need to perform routine maintenance and repair tasks. A list of available Step Saver Kits is included in the Parts List manual which came with your compressor. When ordering Step Saver Kits, please follow the instructions set out below for ordering replacement parts.

ORDERING INSTRUCTIONS

All parts listed in the Part List manual for your compressor are available through your local INGERSOLL-RAND Air Center or Full Service Distributor. Consult the Directory of Distributors included with your compressor to locate the distributor in your area.

When ordering replacement parts or Step Saver Kits, please specify:

1. The MODEL and SERIAL NUMBER as stamped on the compressor nameplate.
2. The FORM NUMBER of the Parts List manual.
3. The QUANTITY, DESCRIPTION and PART NUMBER exactly as listed.

EXAMPLE

Send the following parts for model	7100
Serial Number	T30000000
Literature Form Number	SCD-478A
1 Switch, Pressure - NEMA 1	37005907
2 Element, Filter	32012957
1 Gauge, Pressure	32013872

NOTA

EL USO DE PARTES PARA REPARACION DIFERENTES A LAS INCLUIDAS EN LA LISTA DE PARTES APROBADA DE INGERSOLL-RAND PUEDE CREAR CONDICIONES INSEGURAS O FALLAS MECANICAS SOBRE LAS CUALES INGERSOLL-RAND NO TIENE CONTROL. POR LO TANTO INGERSOLL-RAND NO PUEDE SER RESPONSABLE POR EQUIPOS EN LOS QUE SE HAN USADO PARTES NO APROBADAS.

El fabricante se reserva el derecho a hacer cambios o adicionar mejoras sin notificación y sin incurrir en la obligación de hacer dichos cambios o adicionar tales mejoras a productos vendidos previamente.

GLOSARIO

Lista de Partes de Conjuntos de Ensamble

Las partes están listadas en secuencia de desarme en donde sea aplicable. La relación de un artículo con su más alto e inmediato ensamble está indicado por una indentación (•). Por ejemplo en la columna de DESCRIPCIÓN:

Ensamblajes y partes detalladas

- Partes para ensamblajes y partes detalladas
- • Subensambles
- • • Partes detalladas para sub-ensambles etc.

Columna de Ítems

El número de ítem es el asignado a la parte en el listado. Este número de ítem identifica la parte en la ilustración asociada. Las abreviaturas siguientes podrían aparecer en esta columna:

- NI No ilustra.
REF Para la referencia. Refiera a la página e ilustración apropiada.

Columna de Numero de Parte

Todos los números son números de parte INGERSOLL-RAND los cuales deben ser especificados cuando se ordenen los repuestos. Las abreviaturas siguientes podrían aparecer en esta columna:

- NA Significan que la parte no es aplicable a determinados modelos.
NSS Indican que la parte no se vende por separado para determinados modelos. Las letras
* Los Materiales Consumibles (lubricantes, adhesivos, etc.). Comprédirectamente desde un INGERSOLL-RAND Distribuidor de Servicio o Air Center.
** El Número de Parte Varía. Especifique los datos completos de compresor cuando ordenación.

Columna de Descripción

Esta columna de descripción contiene el nombre del artículo estándar con modificadores. La relación de un artículo con su próximo ensamble más alto se muestra en esta columna por una indentación. Siempre incluir la descripción cuando ordenadora conjuntos o partes de reemplazo.

Columna de Cantidad Por Ensamble

Las cantidades especificadas en esta columna son el número de partes usadas por cada ensamble superior y no necesariamente son el número total de partes del modelo en general. Especifique la cantidad deseada cuando partes ordenadoras de reemplazo.

Como Seleccionar Repuestos Recomendados

Este catálogo contiene una lista de partes que está incluidas en cada una de las siguientes clases de repuestos recomendados:

- CLASE 1 MINIMA. Sugerida para uso doméstico donde interrupciones en la continuidad del servicio no son importantes.
CLASE 2 PROMEDIO. Sugerida para servicio doméstico donde algunas interrupciones en la continuidad del servicio no son objetables.
CLASE 3 MAXIMA. Sugerida para exportación o para servicio doméstico donde la interrupción en el servicio es objetable.

Conjuntos de Partes

Los conjuntos de Partes son disponibles para todos los compresores. Estos conjuntos se diseñan para proveer todas las partes usted necesitará desempeñar el mantenimiento de rutina y repara tareas. Una lista de Conjuntos disponibles se incluye en el lista de partes que vino con su compresor. Cuando se ordenen repuestos recomendados o kits prácticos, siga el procedimiento descrito para partes del compresor.

INSTRUCCIONES DE ORDEN DE COMPRA

Todas las partes enumeraron en el Lista de Partes para su compresor son disponibles mediante su Air Center o Distribuidor de Servicio de INGERSOLL-RAND. Consulte el Directorio de Distribuidores incluyó con su compresor para ubicar el distribuidor en su área.

Quando se ordenen repuestos, por favor especifique:

1. El MODELO y NUMERO DE SERIE como está impreso en la placa del compresor
2. El NUMERO DE FORMATO de la lista de partes.
3. La CANTIDAD, DESCRIPCIÓN y NUMERO DE PARTE exactamente como fue listado.

EJEMPLO

Envíe las siguientes partes para un modelo	7100
Número de Serie	T30000000
Número de formato de la literatura	SCD-478A
1 Interruptor, Presión	37005907
2 Elemento, Filtro	32012957
1 Manómetro	32013872

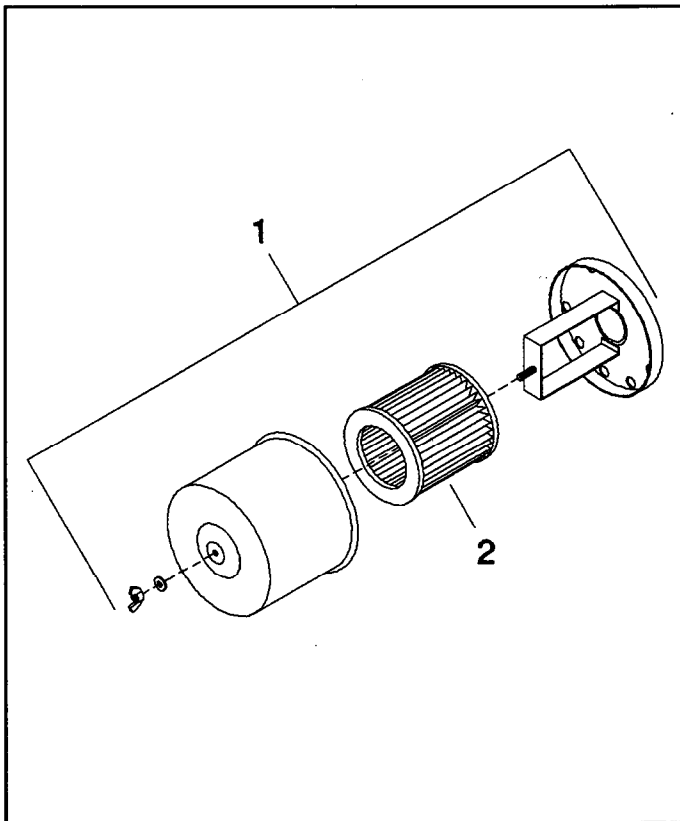

FIGURE 1. INLET FILTER ASSEMBLY

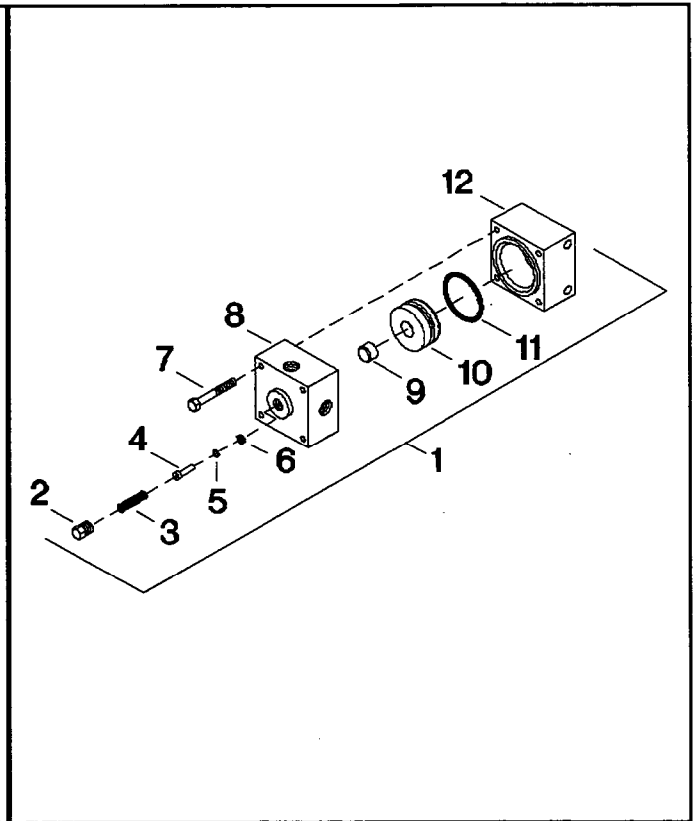

FIGURE 2. UL 104B VALVE

FIGURE 1. INLET FILTER ASSEMBLY

REF. NBR.	PART NUMBER	DESCRIPTION	UNITS PER. ASSY.	REC. SPARES		
				1	2	3
1-1	32109779	FILTER COMPLETE - INLET	1			
1-2	32012957	●ELEMENT, FILTER - 10 MICRON	1	1	1	1
IF FILTER ELEMENT REPLACEMENT IS DESIRED WE RECOMMEND AN ECONOMICAL FILTER KIT. SEE PAGE 14.						

FIGURE 2. UL104B VALVE

REF. NBR.	PART NUMBER	DESCRIPTION	UNITS PER. ASSY.	REC. SPARES		
				1	2	3
2-1	37151172	VALVE, UL 104B	1			
2-2	95372199	●PLUG, PIPE - 1/8	1			
2-3	32106700	●SPRING	1			
2-4	31513534	●VALVE	1			
2-5	95022711	●O-RING	1	1	1	2
2-6	32002065	●RING, BACKUP	1			
2-7	95116745	●CAPSCREW - HEX 1/4-20 x 1-3/4	4			
2-8	30209548	●BODY, VALVE SEAT	1			
2-9	30217624	●SEAT, VALVE - CONDENSATE DRAIN	1	1	1	2
2-10	30221287	●PISTON	1			
2-11	95018420	●O-RING	1	1	1	2
2-12	30823587	●CYLINDER	1			

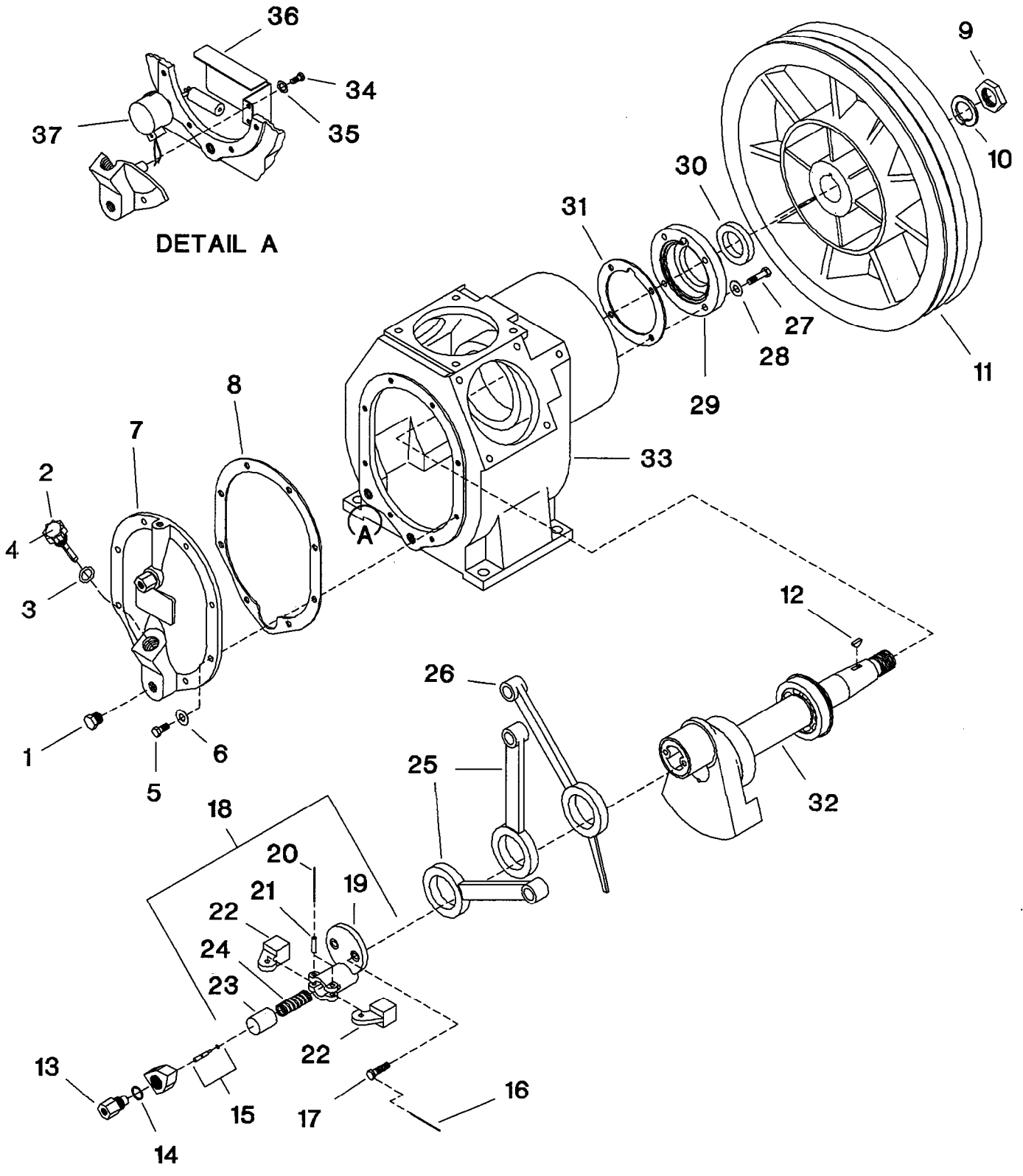

FIGURE 3. COMPRESSOR FRAME ASSEMBLY.

REF. NBR.	PART NUMBER	DESCRIPTION	UNITS PER. ASSY.	REC. SPARES		
				1	2	3
3-1	95344651	PLUG, PIPE - HEX HEAD 1/2"	1			
3-2	30289003	PLUG, OIL FILLER - COMPLETE	1			
3-3	95018149	●O - RING	1	1	1	2
3-4	32000655	DECAL, HAND TIGHTEN	1			
3-5	95053146	CAPSCREW - HEX 3/8-16 x 7/8"	8			
3-6	95674677	GASKET - COPPER WASHER	8			
3-7	37128089	COVER, FRAME END	1			
3-8	30439285	GASKET, FRAME END COVER	1	1	1	2
3-9	30287668	NUT - HEX 3/4-16	1			
3-10	95265690	LOCKWASHER, SPRING - 3/4"	1			
3-11	32003667	WHEEL, V-BELT	1			
3-12	95083721	KEY, WOODRUFF	1			
3-13	37113701	VALVE, PILOT	1		1	1
3-14	30346597	WASHER, COPPER	1			
3-15	32028706	PIN ASSEMBLY, THRUST	1		1	2
3-16	90799289	LOCKWIRE, 20 GA x 5"	1			
3-17	95101929	CAPSCREW - 3/8-16 x 1"	2			
3-18	30210272	CAP ASSEMBLY, CRANKPIN	1			
3-19	30210322	●BODY, CRANKPIN CAP	1			
3-20	90799271	●LOCKWIRE, 12 GA x 4"	1			
3-21	30214951	●PIN, CENTRIFUGAL UNLOADER WEIGHT	2			
3-22	30220875	●WEIGHT, CENTRIFUGAL UNLOADER	2			
3-23	30285688	●PLUNGER, CENTRIFUGAL UNLOADER	1			
3-24	30815898	●SPRING, CENTRIFUGAL UNLOADER	1			1
3-25	32003659	ROD, CONNECTING	2		1	2
3-26	32003642	ROD, CONNECTING	1		1	1
3-27	95053146	CAPSCREW - HEX 3/8-16 x 7/8"	4			
3-28	95674677	GASKET - COPPER WASHER	4			
3-29	37128071	COVER, SHAFT END	1			
3-30	32204562	SEAL, OIL	1		1	2
3-31	30294961	GASKET, SHAFT END COVER	1	1	1	2
3-32	32025694	ASSEMBLY, CRANKSHAFT	1			
3-33	32182602	FRAME, COMPRESSOR	1			
		DETAIL A				
3-34	95053070	CAPSCREW - HEX 1/4-20 x 1/2	2			
3-35	95043196	LOCKWASHER, SPRING - 1/4	2			
3-36	30290043	BAFFLE, LOW OIL LEVEL SWITCH	1			
		OPTIONAL EQUIPMENT				
3-37	32201527	SWITCH, LOW OIL LEVEL	1			
		IF BEARING AND CONNECTING ROD REPLACEMENT IS DESIRED, WE RECOMMEND A BEARING/CONNECTING ROD KIT. SEE PAGE 14.				

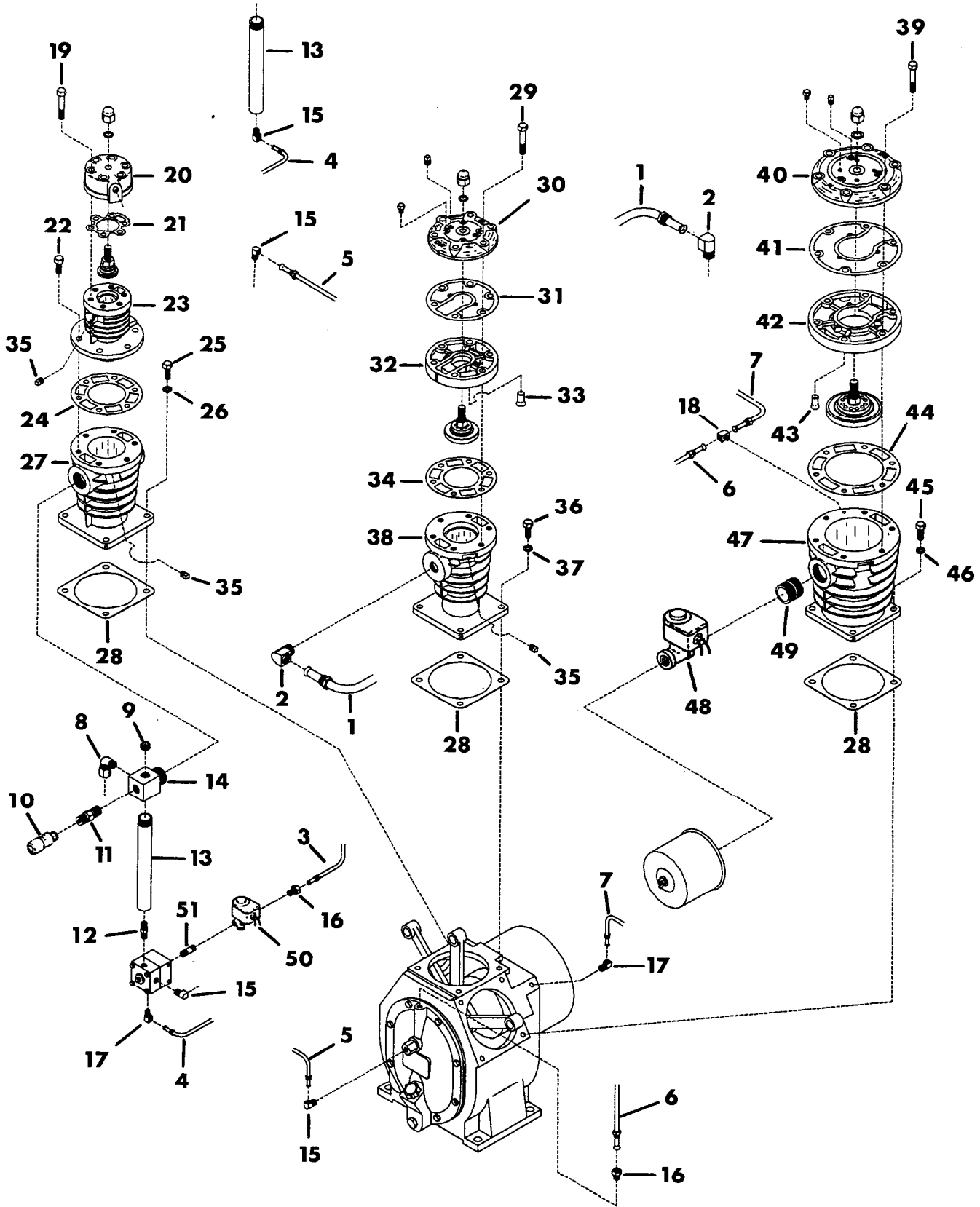
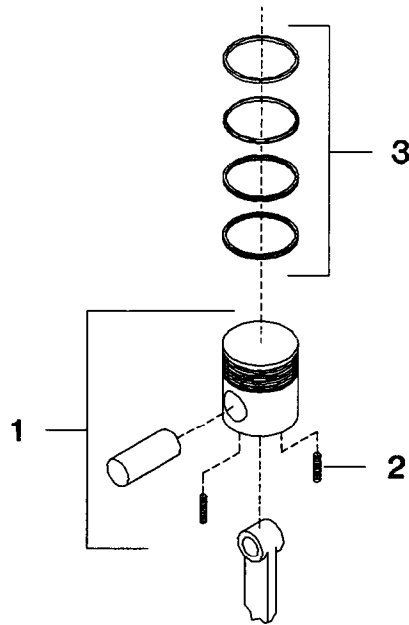
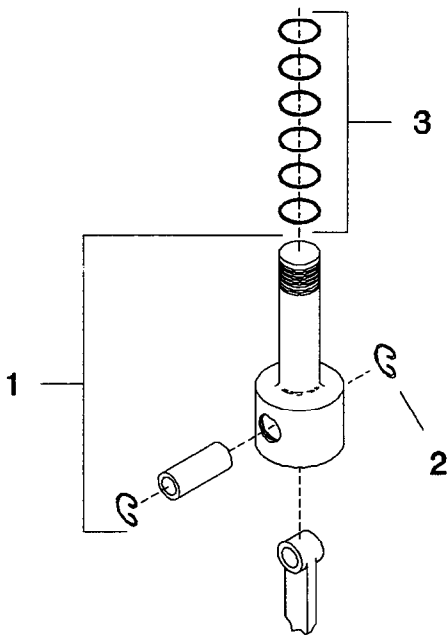

FIGURE 5. MODEL 15T2 BARE COMPRESSOR.

REF. NBR.	PART NUMBER	DESCRIPTION	UNITS PER. ASSY.	REC. SPARES		
				1	1	3
4-1	37131083	TUBE ASSEMBLY, 2nd STAGE/INTERCOOLER	1			
4-2	95031761	TUBE ELBOW - 3/4 x 3/4	2			
4-3	37131166	TUBE ASSEMBLY, CONTROL AIR	1			
4-4	37131182	TUBE ASSEMBLY, 2nd STAGE TRAP/UL104B	1			
4-5	37131075	TUBE ASSEMBLY, 2nd STAGE INTERCOOLER/PILOT VALVE	1			
4-6	37131034	TUBE ASSY., TOP OF FRAME END COVER/1st STAGE CYLINDER	1			
4-7	37131026	TUBE ASSEMBLY, BREATHER	1			
4-8	95098265	TUBE ELBOW - 1/2 x 3/8	1			
4-9	95078648	PLUG, PIPE - SQUARE COUNTERSUNK 1/2	1			
4-10	32162943	VALVE, CHECK - H.P.	1			1
4-11	32166245	NIPPLE, HEX - 1/2	1			
4-12	30214738	NIPPLE, HEX - 1/4	1			
4-13	32003634	LEG, CONDENSATE DRAIN	2			
4-14	30283790	CONNECTION, DRAIN LEG	1			
4-15	95110441	ELBOW, TUBE - 5/16 x 1/4	4			
4-16	32157554	CONNECTOR, MALE - 5/16 x 1/4	2			
4-17	95031860	ELBOW, TUBE - 5/16 x 1/8	2			
4-18	95007522	TEE, MALE BRANCH - 5/16 x 1/8	1			
4-19	95104212	CAPSCREW - HEX 1/2-13 x 2-3/4	6			
4-20	37130655	AIRHEAD - H.P.	1			
4-21	30294284	GASKET, AIRHEAD	1	1	1	2
4-22	95053567	CAPSCREW - HEX 1/2-13 x 1-1/4	6			
4-23	37128675	CYLINDER, AIR - 1.625 INCH	1			
4-24	30294508	GASKET, AIRHEAD	1	1	1	2
4-25	95053567	CAPSCREW - HEX 1/2-13 x 1-1/4	4			
4-26	95674701	GASKET, COPPER WASHER	4			
4-27	37128501	CYLINDER, AIR - CROSSHEAD	1			
4-28	30294235	GASKET, FLANGE	3	3	3	6
4-29	95053666	CAPSCREW - HEX 1/2-13 x 2-3/4	6			
4-30	37130341	AIRHEAD, TOP	1			
4-31	37007754	GASKET, AIRHEAD - TOP/BOTTOM	1	1	1	2
4-32	37130366	AIRHEAD, BOTTOM	1			
4-33	37114030	DOWEL	1			
4-34	30294508	GASKET, AIRHEAD	1	1	1	2
4-35	95033593	PLUG, PIPE - SOLID SQUARE HEAD - 1/4	3			
4-36	95053567	CAPSCREW - HEX 1/2-13 x 1-1/4	4			
4-37	95674701	GASKET, COPPER WASHER	4			
4-38	37128725	CYLINDER, AIR - 3 INCH	1			
4-39	95043790	CAPSCREW - HEX 1/2-13 x 3	6			
4-40	37130531	AIRHEAD, TOP	1			
4-41	37047156	GASKET, AIRHEAD - TOP/BOTTOM	1	1	1	2
4-42	37130556	AIRHEAD, BOTTOM	1			
4-43	37114030	DOWEL	1			
4-44	30294326	GASKET, AIRHEAD	1	1	1	2
4-45	95053567	CAPSCREW - HEX 1/2-13 x 1-1/4	4			
4-46	95674701	GASKET, COPPER WASHER	4			
4-47	37128832	CYLINDER, AIR - 5.5 INCH	1			
NOTE: PARTS LISTED BELOW USED WITH OPTIONAL CONSTANT SPEED						
4-48	32028508	VALVE, SOLENOID - 2 WAY	1			1
4-49	95640108	NIPPLE, CLOSE - 1-1/2 x 1-3/4	1			
4-50	32039778	VALVE, SOLENOID - 3 WAY	1			1
4-51	95376372	NIPPLE, SHORT - 1/4 x 1-1/2	1			



**FIGURE 6.
PISTON/PIN AND RING ASSEMBLY
(3 INCH)**



**FIGURE 5.
PISTON/PIN AND RING ASSEMBLY
(1.625 INCH)**

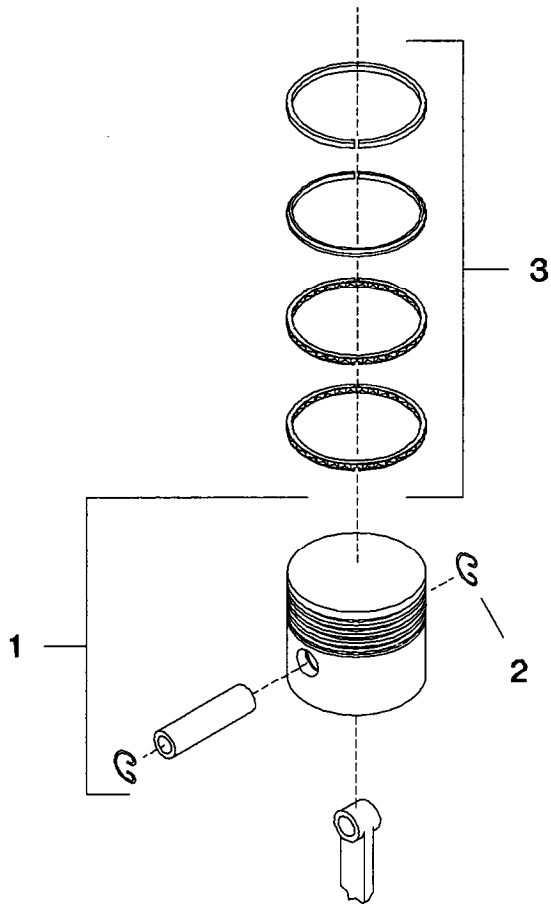

**FIGURE 7.
PISTON/PIN AND RING ASSEMBLY
(5.5 INCH)**

FIGURE 5, 6, 7. PISTON/PIN & RING ASSEMBLIES.

REF. NBR.	PART NUMBER	DESCRIPTION	UNITS PER. ASSY.	REC. SPARES		
				1	2	3
5-1	30215438	FIGURE 5. ASSEMBLY, PISTON/PIN - 1.625 INCH - 3rd STAGE ●RING, LOCK SET, RING IF PISTON RING REPLACEMENT IS DESIRED, WE RECOMMEND AN ECONOMICAL RING/GASKET KIT. SEE PAGE 14.	1		1	1
5-2	30288450		2			
5-3	37138146		1	1	1	2

REF. NBR.	PART NUMBER	DESCRIPTION	UNITS PER. ASSY.	REC. SPARES		
				1	2	3
6-1	30292460	FIGURE 6. ASSEMBLY, PISTON/PIN - 3 INCH - 2nd STAGE ●SETSCREW - HEX 1/4-20 x 1-1/4" SET, RING IF PISTON RING REPLACEMENT IS DESIRED, WE RECOMMEND AN ECONOMICAL RING/GASKET KIT. SEE PAGE 14.	1		1	1
6-2	95065439		2			
6-3	32194276		1	1	1	2

REF. NBR.	PART NUMBER	DESCRIPTION	UNITS PER. ASSY.	REC. SPARES		
				1	2	3
7-1	30215222	FIGURE 7. ASSEMBLY, PISTON/PIN - 5.5 INCH - 1st STAGE ●RING, LOCK SET, RING IF PISTON RING REPLACEMENT IS DESIRED, WE RECOMMEND AN ECONOMICAL RING/GASKET KIT. SEE PAGE 14.	1		1	1
7-2	30288450		2			
7-3	32194144		1	1	1	2

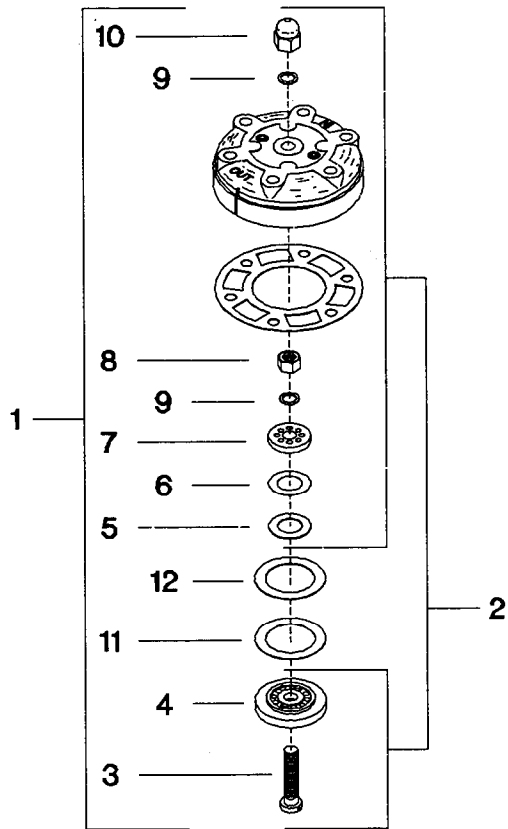

FIGURE 9.
35 GA. VALVE ASSEMBLY

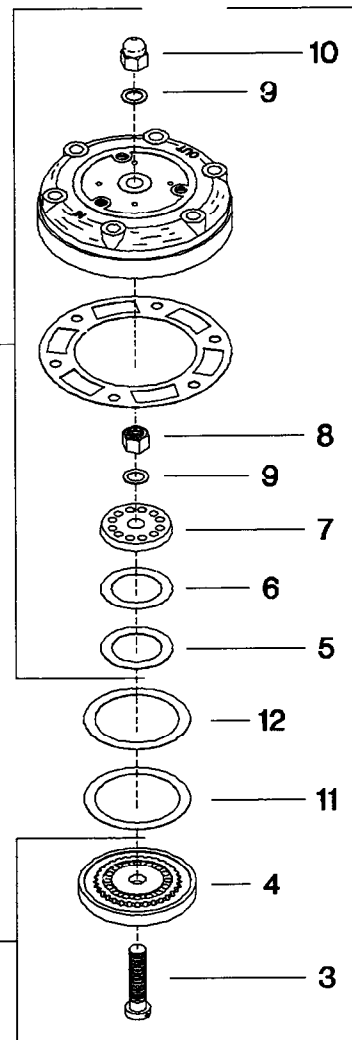

FIGURE 10.
55 GA. VALVE ASSEMBLY

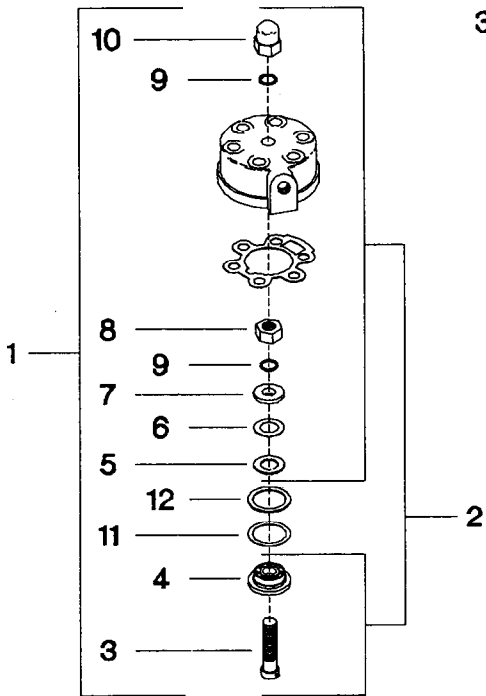

FIGURE 8.
20 GA. VALVE ASSEMBLY

FIGURE 8, 9, 10. VALVE ASSEMBLIES, 15T2 BARE COMPRESSOR.

REF. NBR.	PART NUMBER	DESCRIPTION	UNITS PER. ASSY.	REC. SPARES		
				1	1	3
8-1	31517725	FIGURE 8. VALVE, 20 GA - COMPLETE	1		1	1
8-2	32156697	● VALVE ASSEMBLY	1			
8-3	30220941	● ● BOLT, VALVE	1			
8-4	30217657	● ● SEAT, VALVE-DISCHARGE	1			
8-5	30215925	● ● PLATE, VALVE-DISCHARGE	1	1	1	1
8-6	30221584	● ● SPRING, VALVE-DISCHARGE	1	1	1	1
8-7	30218945	● ● PLATE, STOP-DISCHARGE	1			
8-8	95369229	● ● NUT, HEX - 5/8-18	1			
8-9	32158644	● ● WASHER, BELLEVILLE - 5/8	2			2
8-10	30287643	● ● NUT, ACORN - 5/8-18	1			
8-11	30221493	● SPRING, VALVE-INLET	1	1	1	1
8-12	30215834	● PLATE, VALVE-INLET	1	1	1	1
IF VALVE REPLACEMENT IS DESIRED, WE RECOMMEND AN ECONOMICAL VALVE/GASKET KIT. SEE PAGE 14.						

REF. NBR.	PART NUMBER	DESCRIPTION	UNITS PER. ASSY.	REC. SPARES		
				1	1	3
9-1	37004827	FIGURE 9. VALVE, 35 GA - COMPLETE	1		1	1
9-2	32156713	● VALVE ASSEMBLY	1			
9-3	30220925	● ● BOLT, VALVE	1			
9-4	30217608	● ● SEAT, VALVE-DISCHARGE	1			
9-5	30215941	● ● PLATE, VALVE-DISCHARGE	1	1	1	1
9-6	30221576	● ● SPRING, VALVE-DISCHARGE	1	1	1	1
9-7	30218994	● ● PLATE, STOP-DISCHARGE	1			
9-8	95076808	● ● NUT, HEX - 5/8-18	1			
9-9	32158644	● ● WASHER, BELLEVILLE - 5/8	2			2
9-10	30287643	● ● NUT, ACORN - 5/8-18	1			
9-11	30221501	● SPRING, VALVE-INLET	1	1	1	1
9-12	30181499	● PLATE, VALVE-INLET	1	1	1	1
IF VALVE REPLACEMENT IS DESIRED, WE RECOMMEND AN ECONOMICAL VALVE/GASKET KIT. SEE PAGE 14.						

REF. NBR.	PART NUMBER	DESCRIPTION	UNITS PER. ASSY.	REC. SPARES		
				1	1	3
10-1	37101946	FIGURE 10. VALVE, 55 GA - COMPLETE	1		1	1
10-2	32156747	● VALVE ASSEMBLY	1			
10-3	30279897	● ● BOLT, VALVE	1			
10-4	30217673	● ● SEAT, VALVE-DISCHARGE	1			
10-5	30181499	● ● PLATE, VALVE-DISCHARGE	1	1	1	1
10-6	30221501	● ● SPRING, VALVE-DISCHARGE	1	1	1	1
10-7	30218978	● ● PLATE, STOP-DISCHARGE	1			
10-8	95076816	● ● NUT, HEX - 3/4-16	1			
10-9	37092897	● ● WASHER, BELLEVILLE - 3/4	2			2
10-10	30287650	● ● NUT, ACORN - 3/4-16	1			
10-11	30221550	● SPRING, VALVE-INLET	1	1	1	1
10-12	30215891	● PLATE, VALVE-INLET	1	1	1	1
IF VALVE REPLACEMENT IS DESIRED, WE RECOMMEND AN ECONOMICAL VALVE/GASKET KIT. SEE PAGE 14.						

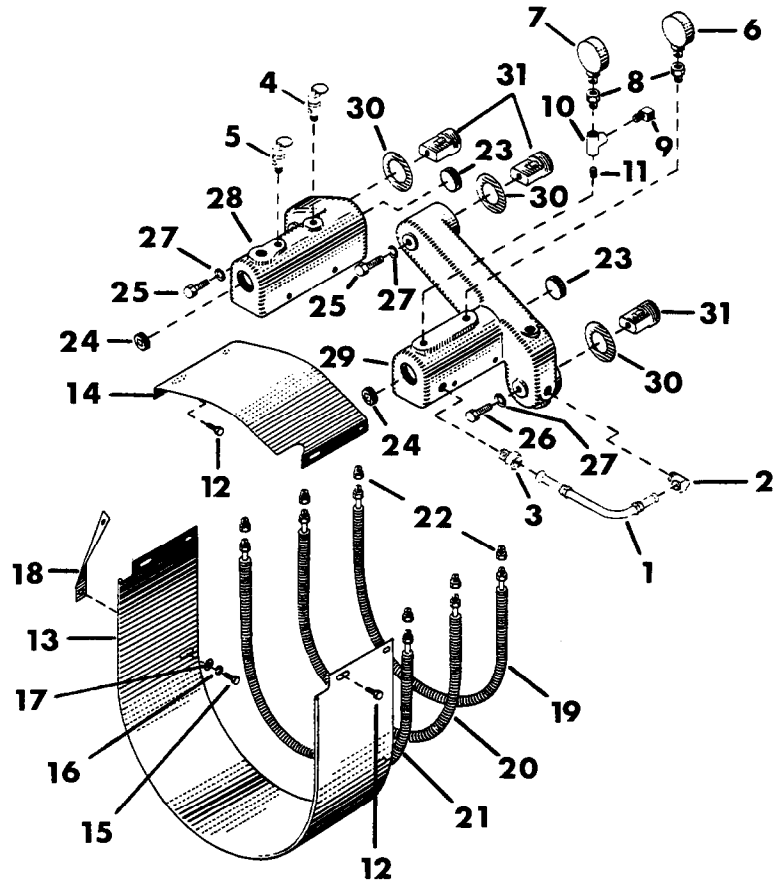

FIGURE 11. 15T2 INTERCOOLER ASSEMBLY.

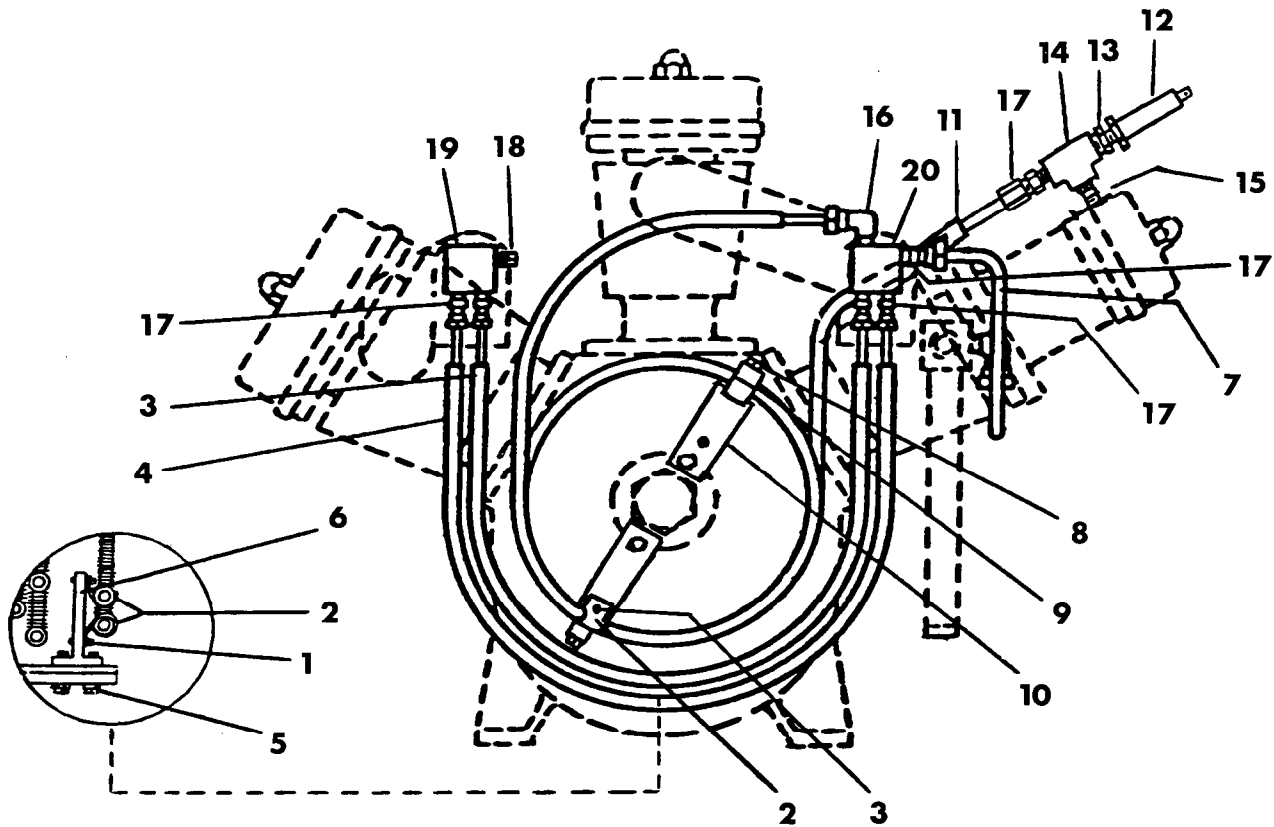

FIGURE 12. 15T2 AFTERCOOLER ASSEMBLY.

REF. NBR.	PART NUMBER	DESCRIPTION	UNITS PER. ASSY.	REC. SPARES		
				1	1	3
11-1	37131109	FIGURE 11. 15T2 INTERCOOLER ASSEMBLY.				
		ASSEMBLY, TUBE - INTERCOOLER/3rd STAGE	1			
11-2	95031761	ELBOW, TUBE - 3/4 x 3/4	1			
11-3	95083275	CONNECTOR, TUBE - 3/4 x 3/4	1			
11-4	72062151	VALVE, SAFETY - 60 PSIG	1			1
11-5	32174799	VALVE, SAFETY - 260 PSIG	1			1
11-6	32127896	GAUGE, PRESSURE - 100 PSIG	1			1
11-7	32013898	GAUGE, PRESSURE - 300 PSIG	1			1
11-8	30282396	DAMPENER ASSEMBLY - PULSATION	2			
11-9	95110441	ELBOW, TUBE - 1/4	1			
11-10	95006524	TEE, PIPE - 1/4	1			
11-11	95426714	NIPPLE, CLOSE - 1/4 x 7/8	1			
11-12	32175572	CAPSCREW - HEX 1/4-20 x 1/2	8			
11-13	32204471	SHROUD, INTERCOOLER - BOTTOM	1			
11-14	30218325	SHROUD, INTERCOOLER - TOP	1			
11-15	95053070	CAPSCREW - HEX 1/4-20 x 1/2	1			
11-16	95094298	WASHER, FLAT - 1/4	1			
11-17	95043196	LOCKWASHER, SPRING - 1/4	1			
11-18	30209829	BRACE, INTERCOOLER SHROUD	1			
11-19	32024697	TUBE ASSEMBLY, FINNED - 36"	7	1		2
11-20	32025678	TUBE ASSEMBLY, FINNED - 38-3/4"	5	1		2
11-21	32025686	TUBE ASSEMBLY, FINNED - 41-1/2"	7	1		2
11-22	95083143	CONNECTOR, MALE - 3/8 x 1/4"	38			
11-23	95033338	PLUG, SQUARE COUNTERSUNK - 1-1/4"	2			
11-24	32186413	PLUG, SQUARE COUNTERSUNK - 1"	2			
11-25	95043808	CAPSCREW - HEX 5/8-11 x 2-1/4	1			
11-26	95002168	CAPSCREW - HEX 5/8-11 x 2-1/2	2			
11-27	30345185	WASHER, FLAT - 5/8	3			
11-28	37129038	MANIFOLD, INTERCOOLER	1			
11-29	37129046	MANIFOLD, INTERCOOLER	1			
11-30	30294870	GASKET, MANIFOLD	3	1	1	2
11-31	30221121	CONNECTION, MANIFOLD	3			

REF. NBR.	PART NUMBER	DESCRIPTION	UNITS PER. ASSY.	REC. SPARES		
				1	2	3
12-1	32175572	FIGURE 12. 15T2 AFTERCOOLER ASSEMBLY.				
		CAPSCREW - HEX 1/4-20 x 1/2"	3			
12-2	32065641	CLAMP, TUBE - 3/4"	3			
12-3	30335459	TUBING, FINNED - 41 INCH	1			
12-4	30335442	TUBING, FINNED - 37 INCH	1			
12-5	95079703	CAPSCREW - HEX 3/8-16 x 1/2	2			
12-6	37129053	BRACE	1			
12-7	37131125	TUBE ASSEMBLY, AFTERCOOLER/TRAP	1			
12-8	95043766	CAPSCREW - HEX 3/8-16 x 1-1/4	4			
12-9	30209795	CLAMP, AFTERCOOLER	2			
12-10	32006991	BRACE, AFTERCOOLER	2			
12-11	30335525	TUBING, FINNED - AFTERCOOLER	1			1
12-12	32203267	VALVE, SAFETY - 1400 PSI	1			1
12-13	32179046	BUSHING, REDUCING - 3/8 x 1/4	1			
12-14	95007852	TEE, PIPE - 3/8	1			
12-15	95554630	NIPPLE, SHORT - 3/8 x 1-1/2	1			
12-16	95098265	TUBE ELBOW - 1/2 x 3/8	1			
12-17	95229571	CONNECTOR, TUBE - 1/2 x 3/8	6			
12-18	95033601	PLUG, PIPE - SOLID SQUARE HEAD 3/8	1			
12-19	30284137	CONNECTION, AFTERCOOLER - (3 HOLES)	1			
12-20	30284152	CONNECTION, AFTERCOOLER - (4 HOLES)	1			

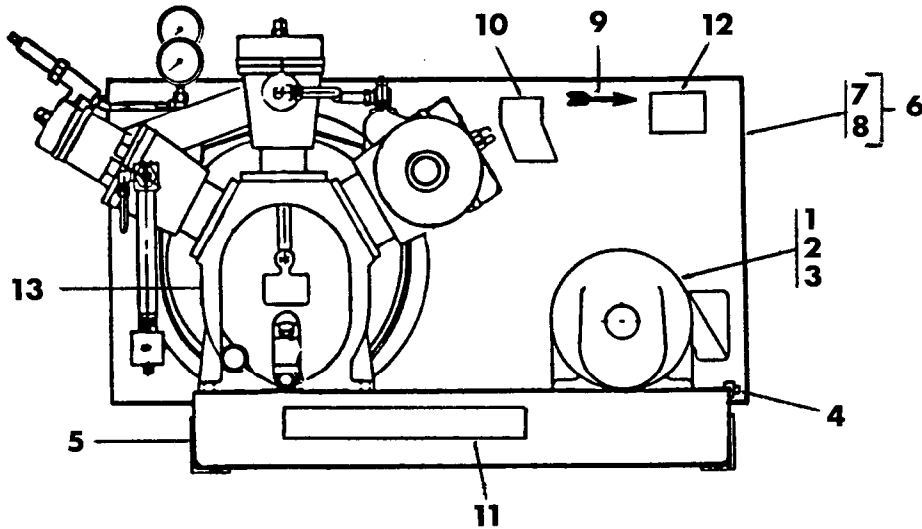

FIGURE 7. COMPRESSOR DRIVE, SUB-BASE, AND ACCESSORIES.

REF. NBR.	PART NUMBER	DESCRIPTION	UNITS PER. ASSY.	REC. SPARES		
				1	2	3
7-1	*	MOTOR, ELECTRIC	1			
7-2	32118192	PULLEY, MOTOR - 10HP 555 RPM	1			
7-2	32118135	PULLEY, MOTOR - 15HP 750 RPM	1			
7-2	32128910	PULLEY, MOTOR - 15HP 900 RPM	1			
7-3	95100541	BELT, "V" - 555 & 750 RPM	3			3
7-3	95100558	BELT, "V" - 900 RPM	3			3
7-4	32188708	TIGHTENER, BELT - COMPLETE	1			
7-5	32001778	SUB-BASE ASSEMBLY	1			
7-6	32002644	BELTGUARD - COMPLETE	1			
7-7	32003410	●BACK, BELTGUARD	1			
7-8	32003329	●COVER, BELTGUARD	1			
7-9	30286686	DECAL, ROTATION ARROW	1			
7-10	32022923	DECAL, T30	1			
7-11	30288054	DECAL, INGERSOLL-RAND	1			
7-12	32015620	DECAL, MAINTENANCE	1			
7-13	97003636	DECAL, DANGER	1			
		OPTIONAL EQUIPMENT				
***	37005840	SWITCH, PRESSURE - NEMA 1 - FOR 260 TO 600 PSI	1			
***	37005857	SWITCH, PRESSURE - NEMA 1 - FOR 601 TO 1000 PSI	1			
***	32190712	SWITCH, HIGH AIR TEMPERATURE - NEMA 1, 4, 12, & 13	1			
***	32190738	THERMOWELL, 1/2" - 1000 PSI	1			

* Specify discharge pressure of compressor and complete motor nameplate data.

** Purchase from your local Ingersoll-Rand Distributor.

*** Not Shown in Illustration

STEP SAVER KIT

For your convenience, the following parts and/or spare parts for your compressor are available in parts kits. When ordering the kits below, use kit names as Description and the Part No. as shown.

PART NO.	DESCRIPTION
32166787	KIT, FILTER
32133951	KIT, VALVE/GASKET
32133969	KIT, RING/GASKET
32127516	KIT, BEARING/CONNECTING ROD
30423339	KIT, GASKET

⚠ WARNING

STATEMENT CONCERNING THE USE OF THIS EQUIPMENT FOR BREATHING AIR AND/OR AQUA LUNG SERVICE.

If the model number on a compressor contains the letters "BAP", the air compressor is suitable for breathing air services. Compressors that DO NOT bear this designation are NOT capable of producing air of breathing quality. For use in breathing air applications, an air compressor must be fitted with additional specialized equipment to properly filter and/or purify the air to meet all applicable federal, state and local laws, rules, regulations and codes, such as, but not limited to, OSHA 29 CFR 1910.34. Compressed Gas Association Commodity Specifications G-7.1-1966. Grade D Breathing Air, and/or Canadian Standards Association. Should the Purchaser and/or User fail to add such specialized equipment, and proceed to use the air compressor for breathing air service, the Purchaser/User assumes all liability resulting therefrom without any responsibility or liability being assumed by Ingersoll-Rand Company.

The purchaser is urged to include the above provisions in any agreement for any resale of this compressor.

Hazardous vapors. Can cause severe nausea, fainting or death.

Compressed air or gas from this compressor may contain poisonous vapors or gases.

Certain sprayed material such as paints, insecticides, weed killer, sand, etc., may be harmful if inhaled or used in a closed area.

Never directly inhale the compressed air or gas produced by this compressor.

Always read container labels when spraying paints or poisons.

Always use the compressor in a well-ventilated area.

Use a respirator or mask whenever there is a chance that you might inhale any sprayed material. If a mask is used, read all instructions provided with the mask to ensure it will protect you from the materials you are spraying.



Hazardous voltage. Can cause severe injury or death.

Always disconnect the power supply cord before performing any maintenance or repair work.

Always connect the power supply cord to a grounded electrical receptacle with the specified voltage and fuse protection.

Never use the compressor in rain, in a wet area, or near an explosive environment.



Flammable vapors. Can cause a fire or explosion, and result in severe injury or death.

Sparks from the motor's electrical contacts can ignite flammable vapors from gasoline, natural gas or solvents.

Do not operate the compressor in any areas where explosive or flammable vapors or liquids may exist.

Never smoke or use open flame in the vicinity of the compressor or any gas bottle or source.



Compressed air/gas has great force.

Over-pressurizing the bottle, tank or receiver, or using a receiver which does not meet the design limits for this compressor, can cause them to rupture or explode, and result in severe injury or death.

Changes to the bottle, tank or receiver structure will cause it to weaken and can cause it to rupture or explode, and result in severe injury or death.

Internal rusting in the bottle, tank or receiver will cause it to weaken and can cause it to rupture or explode, and result in severe injury or death.

Pressure beyond design limits can cause the bottle, tank or receiver to rupture or explode, and result in severe injury or death.

Improper use of air tools or attachments can cause an explosion, and result in severe injury or death.

The bottle, tank or receiver is equipped with a relief valve to protect against over-pressurization. DO NOT REMOVE, ADJUST OR MAKE SUBSTITUTIONS FOR THE RELIEF VALVE. Periodically pull the ring on the relief valve to ensure it operates freely. If the valve is stuck or does not operate freely, it must be replaced.

Never drill into, weld to, or alter the bottle, tank or receiver in any manner.

Drain water/condensate from the air receiver daily or before each use.

Pressure switch and unloader valve operation is related to motor/engine horsepower, air receiver rating, and relief valve setting. DO NOT ATTEMPT TO ADJUST, REMOVE OR BYPASS THE PRESSURE SWITCH, OR CHANGE OR MODIFY ANY PRESSURE CONTROL RELATED DEVICE.

Do not use any air tools or air attachments without first determining the maximum air pressure recommended for that particular piece of equipment.

Compressed natural gas compressors are equipped with explosion-proof electrical systems. Ensure any additional electrical equipment is also explosion-proof.

Gas leaks can occur in compressed natural gas compressors or associated piping. Even small leaks pose a potential hazard and should be corrected before the compressor is operated. If a maintenance function involves breaking a gas-tight joint, always recheck for gas leaks after reassembling by using a commercial gas leak detector.



Rotating compressor. Can propel dirt, sand, metal shavings, etc., and result in severe injury.

Never point an air nozzle or air sprayer toward any part of the body, or toward another person.

Always wear safety glasses or goggles when servicing.



Moving parts. Can cause severe injury.

Always disconnect the power supply before attempting to perform any maintenance or repair work.

Always ensure the pressure is released from the compressor, bottles, tanks, receiver and air attachments before performing any maintenance or repair work.

Always disconnect the power supply on electric motor models if the compressor is to be left unattended.

Never operate compressor with the fan shroud removed, or if the shroud is damaged or broken.



Hot parts. Compressors get hot while running, and can cause severe burns if touched.

Never touch the compressor, motor/engine, or tubing during or shortly after compressor operation.



⚠ ADVERTENCIA

DOCUMENTO CONCERNIENTE AL USO DE ESTE EQUIPO PARA EL SERVICIO DE AIRE RESPIRABLE Y/O SERVICIO DE BUCEO.

Si el número del modelo en un compresor de aire contiene las letras BAP, el compresor está diseñado para el uso en servicios de aire respirable. En la ausencia de tal designación, el compresor no puede ser considerado adecuado para producir aire respirable. Para que un compresor sea adecuado para ser usado en aplicaciones de aire respirable, debe estar acondicionado con equipo especializado para filtrar y/o purificar apropiadamente el aire y así cumplir con las leyes, reglas y regulaciones federales, locales y estatales, no limitadas a OSHA 29 CFR 1910.34, las Especificaciones de la Asociación de Gas Comprimido G-7.1-1966 Aire respirable Grado D, y/o Asociación de Estándares Canadienses. Si el comprador y/o el usuario no añaden este equipo especializado y procede a usar el compresor para servicio de aire respirable, el Comprador/Usuario asume toda la responsabilidad resultante de esto sin que ninguna responsabilidad u obligación sea asumida por la compañía Ingersoll-Rand.

Se sugiere al comprador que incluya la anterior provisión en cualquier acuerdo por cualquier re-venta de este compresor.

Vapores peligrosos. Pueden causar náusea, desmayo o muerte.

El aire comprimido de este compresor puede contener monóxido de carbono venenoso.

Ciertos materiales propulsados por aire tales como pinturas, insecticidas, arena etc. pueden ser peligrosos si se inhalan o utilizan en un área cerrada.

Nunca inhale directamente el aire comprimido producido por este compresor.

Lea siempre las etiquetas de los contenedores cuando esté rociando pintura o venenos.

Siempre utilice el compresor en un área bien ventilada.

Utilice el respirador o máscara cuando haya riesgo de inhalar cualquier material que esté rociando. Si utiliza máscara, lea muy bien las instrucciones para que usted pueda saber de qué lo va a proteger mientras rocía.

Voltaje peligroso. Puede causar heridas severas o muerte.

Siempre desconecte el suministro eléctrico antes de hacer cualquier mantenimiento o reparación.

Siempre conecte el suministro eléctrico a un circuito adecuado y con el voltaje especificado.

Nunca utilice el compresor en la lluvia, o en un área cerca de una atmósfera explosiva.

Vapores inflamables. Pueden causar fuego o una explosión, y el resultado puede ser herida severa o muerte.

Chispas del motor eléctrico pueden encender vapores inflamables de gasolina, gas natural o solventes.

No operen el compresor en ningunas áreas donde vapores o los líquidos explosivos o combustibles pueden existir.

Nunca fumar o el uso abre llama en la vecindad del compresor, botella de gas o fuente de gas.

El aire comprimido tiene gran fuerza.

El tanque de aire sobre-pressurizado puede causar que el tanque de aire explote o se rompa, y puede resultar en heridas severas o muerte.

Cambios en la estructura del tanque de aire pueden causar que el tanque de aire se debilite causando la ruptura o explosión de este, resultando en herida severa o muerte.

El debilitamiento de la estructura del tanque de aire debido a oxidación interna puede causar rupturas o explosión del tanque y puede resultar en heridas severas o muerte.

La presión de aire fuera de sus límites puede causar que el tanque explote o se rompa, y esto causaría heridas severas o muerte.

El uso impropio de las herramientas neumáticas o sus accesorios pueden causar explosión, y resultar en heridas severas.

El tanque de aire está protegido de sobrepresurización por una válvula de seguridad. NOQuite, haga ajustes, o sustituciones en esta válvula. Ocasionalmente hale el anillo en la válvula de seguridad para asegurarse de que la válvula funcione libremente. Si la válvula está atascada o no funciona, debe ser reemplazada.

Nunca perfore, sude o cambie el tanque de aire en ninguna forma.

Drene el agua/condensado del tanque de aire diariamente o antes de cada uso.

NO TRATE DE AJUSTAR, REMOVER, O DERIVAR EL BOTÓN DEL INTERRUPTOR DE PRESIÓN, O CAMBIE Y MODIFIQUE CUALQUIER ESTRUCTURA RELACIONADA CON EL CONTROL DE PRESIÓN.

No utilice ninguna herramienta neumática o accesorio sin determinar la presión máxima de aire comprimido que se recomienda para esa herramienta en particular.

Los compresores comprimidos de gas natural se equipan con sistemas eléctricos que no estallarán. Asegure cualquier equipo eléctrico adicional es también incapaz de estallar.

Los escapes de gas pueden ocurrir en los compresores naturales de gas o asociados tubos. Cualquier escape es un peligro potencial y debería corregirse antes de que el compresor se opera. Si una función de mantenimiento involucra quitando un sujetador, siempre detecta cualquier gas escapa después de armar nuevamente por usar un detector de escape de gas.

Aire comprimido. Puede expulsar polvo, metal o arena etc. y puede resultar en heridas.

Nunca apunte la boquilla hacia alguna parte del cuerpo o hacia otra persona.

Use siempre gafas protectoras.

Las partes en movimiento pueden causar heridas severas.

Desconecte siempre el suministro eléctrico antes de cualquier mantenimiento ó reparación.

Desconecte siempre el suministro eléctrico si el compresor no va ser usado.

Asegúrese que el aire a presión es liberado del compresor, del tanque de aire, y demás accesorios de aire antes de hacer cualquier mantenimiento o reparación.

Nunca opere el compresor sin el guarda poleas. Nunca opere el compresor con una polea dañada o rota.

Partes calientes. Los compresores de aire se calientan en operación y pueden causar quemaduras severas.

Nunca toque el compresor, el motor, o la tubería de descarga durante o poco después de operar el compresor.

**Look What INGERSOLL-RAND
Can Do For YOU. . .**

**Vea Lo Que INGERSOLL-RAND
Puede Hacer Por USTED. . .**

EFFICIENT FIELD SERVICE

We maintain a highly trained staff of technicians to service your equipment for preventive maintenance, or to assist you should emergencies ever occur.



EFICIENTE SERVICIO EN EL CAMPO

Mantenemos un grupo de mecánicos entrenados para suministrarle mantenimiento preventivo o atender cualquier emergencia que puede tener.

COMPLETE REPAIR SERVICE

Our trained technicians will repair or overhaul your equipment to factory specifications, using only genuine I-R parts.



COMPLETO SERVICIO DE REPARACION

Mecánicos entrenados repararán su compresor según los métodos recomendados por fábrica usando solamente partes genuinas Ingersoll-Rand.

SPECIAL ENGINEERING SERVICE

We can help you identify and solve your compressed air problems by evaluating your needs and recommending the proper compressor and air piping system to give you maximum efficiency.

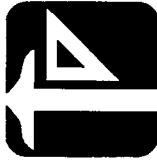

SERVICIO DE INGENIERIA ESPECIAL

Nosotros podemos ayudarlo con sus problemas de aire comprimido investigando sus necesidades y recomendando el compresor y el sistema de aire adecuados para lograr máxima eficiencia.

SPARE PARTS

By stocking genuine I-R spare parts, we can help you avoid costly delays, or substituting inferior parts. Using genuine I-R parts on your I-R equipment will help to keep even older machines running in good-as-new condition.



PARTES DE REPUESTO

Mantenemos partes genuinas Ingersoll-Rand, evitando posibles sobrecostos debido a demoras en la sustitución de partes menores. Como resultado, los equipos antiguos son mantenidos como nuevos.

COMPLETE STOCK OF EQUIPMENT

We carry a complete line of I-R equipment and accessories designed to meet any compressed air application. We are backed by Ingersoll-Rand's prompt factory shipment to ensure you on-time delivery.

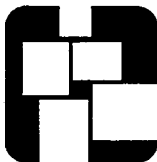

STOCK COMPLETO DE EQUIPOS

Nuestro stock de máquinas completas que pueden encargarse usualmente de cualquier necesidad, está soportado por un eficiente sistema de despachos de fábrica de Ingersoll-Rand para asegurarle entrega a tiempo.

A SUBSTITUTE IS NOT A REPLACEMENT

Ensure you get peak performance and longevity out of your Ingersoll-Rand compressor by insisting on genuine Ingersoll-Rand replacement parts and maintenance kits. Not only are the replacement parts made to precise dimensions and OEM-specified metallurgy, but each part is backed by the Ingersoll-Rand warranty. Your local Air Center, Full-Service distributor or direct Ingersoll-Rand salesperson will work with you to ensure you get the parts you need to do the job right. Equip your machines with only the best - Ingersoll-Rand Genuine Parts.

UN SUSTITUO NO ES UN REEMPLAZO

Asegúrese que obtiene máximo desempeño y duración de su compresor insistiendo en usar solamente partes de reemplazo genuinas y kits de mantenimiento Ingersoll-Rand. No solamente están construidas con dimensiones precisas y especificaciones exactas de metallurgia, sino que cada parte está respaldada por la garantía Ingersoll-Rand. Su Air Center, su Distribuidor de Servicio o el personal de ventas directo de Ingersoll-Rand trabajarán con Usted para asegurarle que recibe las partes para efectuar el trabajo correcto. Equipe sus máquinas sólo con lo mejor - Partes Genuinas Ingersoll-Rand.

**DISTRIBUTED BY:
DISTRIBUIDO POR:**



**Ingersoll-Rand Company
Reciprocating Compressor Division
Small Compressor Business Unit
Campbellsville, KY 42718**